

EATON Airflex

Airflex® WCB2 & WCBD Brakes

Designed for continuous slip service, these units can absorb and dissipate the thermal loads found in severe applications.



WCB2 & WCBD Description

WCB elements are disc type, externally cooled units. They are designed to absorb and dissipate the thermal loads associated with the most severe clutch and brake applications. The WCB friction couple was developed specifically for continuous slip service and has a dynamic coefficient of friction. Special high coefficient linings are also available which provide 50% higher torque than standard friction linings and provide 1:1 dynamic to static torque ratio.

Element construction and operation is illustrated in the figure. Pressurizing the cylinder causes the piston to clamp the friction disc between the water jackets. Heat generated at the friction interfaces is quickly transferred to the circulating coolant.

Element sizes are indicated by the number of friction discs and the disc diameter in inches. For instance, size 224WCB has two friction discs 24 inches in diameter.

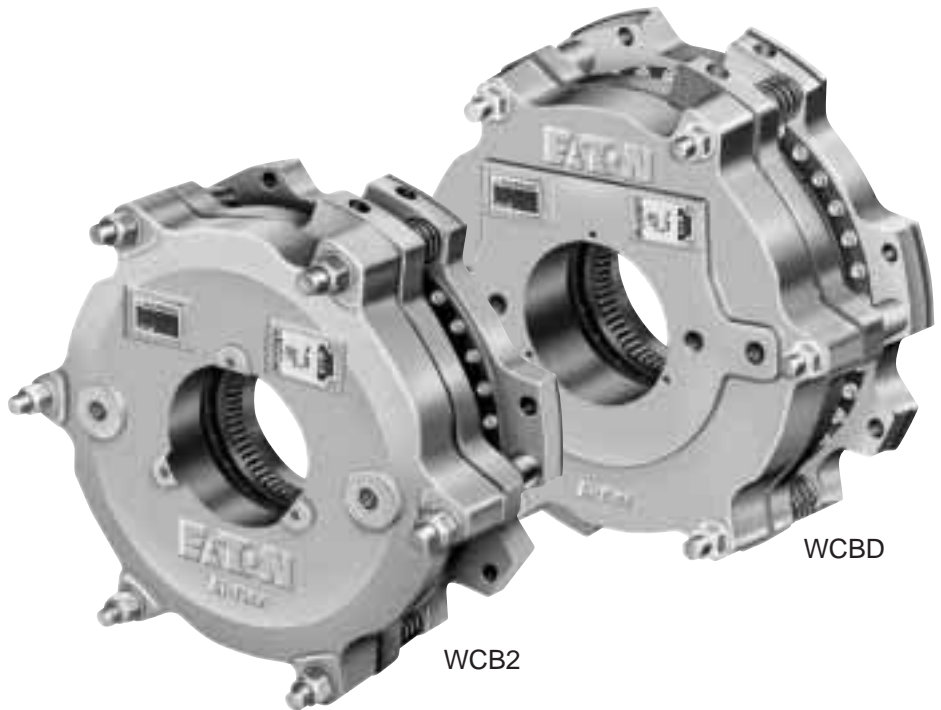

Features:

Patented piston design

Single or dual piston provides wider range of applied tension with greater control.

Drop in powerhead package

Standard single piston elements can be retrofitted with a dual piston powerhead to provide increased control.

Unique friction couple

A specially formulated friction material, interfacing with a copper alloy surface, eliminates the stick-slip characteristic associated with ordinary frictional devices.

Rapid heat dissipation

The copper interface conducts heat rapidly to the circulating coolant.

Open or closed loop coolant systems

The element works equally well with open or closed loop circulating systems. On mobile equipment, the engine's cooling system can be tapped to provide coolant to the element.

Optional corrosion protection

For marine environment applications, protective coatings are available to minimize corrosion.

Where used:

- Dynamometers
- Logging equipment
- Marine mooring systems
- Slip clutches
- Tension brakes
- Unwind stands

WCB2 & WCBD Component Parts

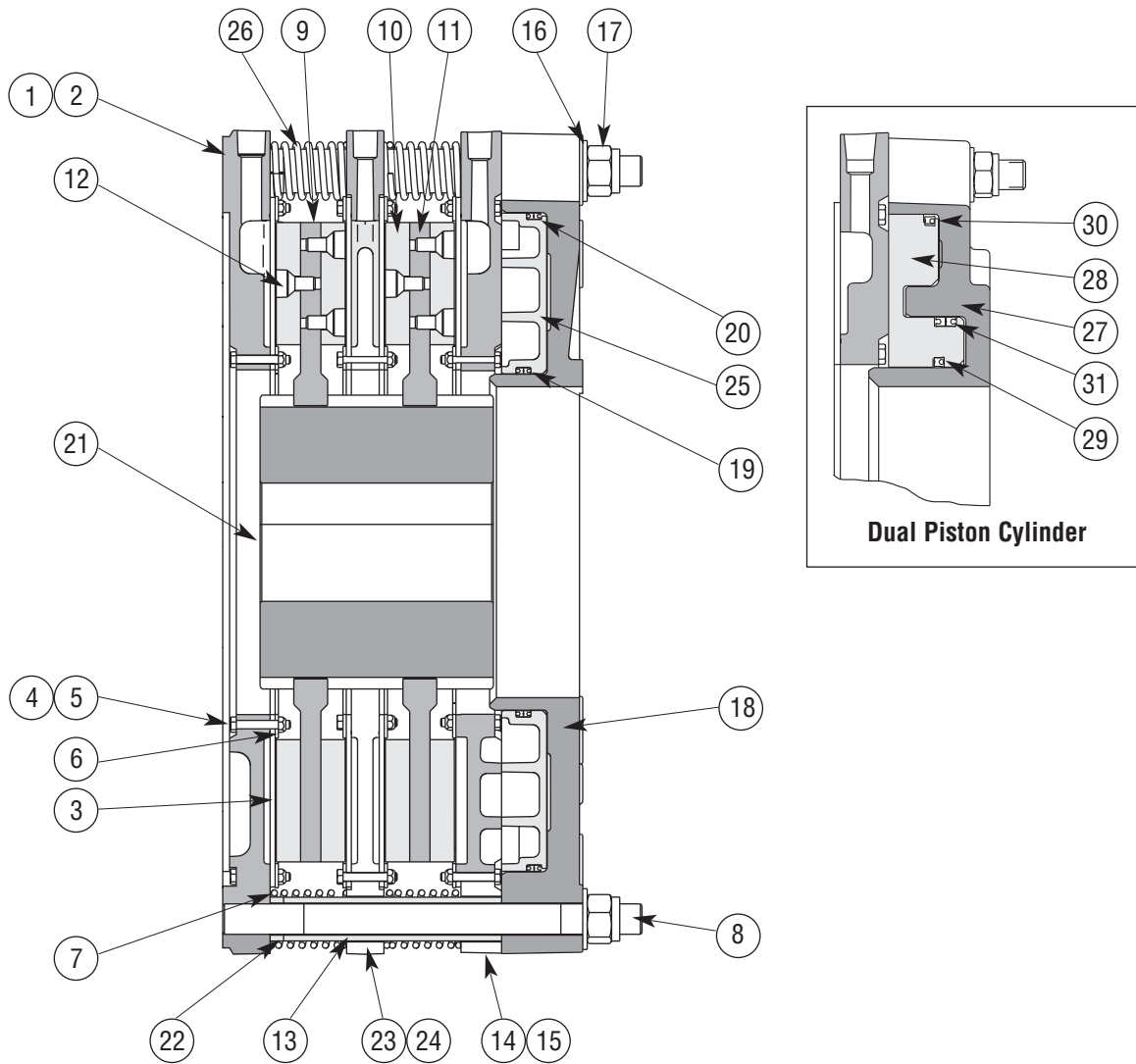

Item	Description	Item	Description
1	Mounting Flange Sub-Assembly	17	Lock Nut
2	Mounting Flange	18	Cylinder
3	Wear Plate	19	Inner Seal
4	Hex Head Screw	20	Outer Seal
5	Locknut	21	Gear
6	Inner Support Ring	22	Wear Spacer
7	Outer Support Ring	23	Reaction Plate Sub-Assembly
8	Stud	24	Reaction Plate
9	Friction Disc Sub-Assembly	25	Piston
10	Friction Disc	26	Release Spring
11	Friction Disc Core	27	Dual Piston Cylinder
12	Flat Head Screw	28	Dual Piston
13	Clamp Tube	29	Dual Piston Inner Seal
14	Pressure Plate Sub-Assembly	30	Dual Piston Outer Seal
15	Pressure Plate	31	Dual Piston Intermediate Seal
16	Flat Washer		

Note:

① Dual disc unit shown. Other multi-disc units are similar. Items 23 and 24 are not required for single disc units.

WCB2 & WCB Elements— Dimensional Data*

Mounting Bolt Circles¹

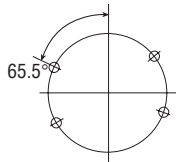

Coolant Inlet Port
8WCB
(4) 0.531 (13,5)Ø Dia.
Mounting holes based on
6 equally spaced as
shown on 11.125
(282,5) bolt circle

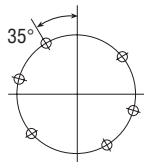

Coolant Inlet Port
14WCB
(6) 0.656 (16,7)Ø Dia.
Mounting holes based on
8 equally spaced as
shown on 17.500
(444,5) bolt circle

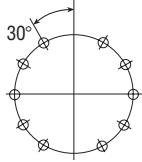

Coolant Inlet Port
18WCB
(10) 0.656 (16,75)Ø Dia.
Mounting holes based on
12 equally spaced
as shown on 22.000
(558,8) bolt circle

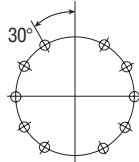

Coolant Inlet Port
24WCB
(10) 0.656 (16,75)Ø Dia.
Mounting holes based on
12 equally spaced
as shown on 28.750
(730,3) bolt circle

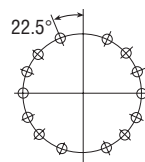

Coolant Inlet Port
36WCB
(14) 1.062 (27,0)Ø Dia.
Mounting holes based on
16 equally spaced as
shown on 42.000
(1066,8) bolt circle

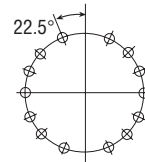

Coolant Inlet Port
48WCB
(14) 1.438 (36,5)Ø Dia.
Mounting holes based on
16 equally spaced as
shown on 54.000
(1371,6) bolt circle

* Data shown is subject to change. Please consult factory for current dimensional data.

English	Dimensions in inches												
8WCB	0.81	1.25	0.250	7	2.62	12.125	8	1/2-13	10.875	4.12	8.375	3.12	12.24
14WCB	0.91	1.41	0.250	8	2.90	18.750	8	3/4-10	17.000	7.12	14.375	6.00	18.94
18WCB	0.93	1.47	0.250	1.25	3.14	23.25	12	3/4-10	21.750	11.00	18.250	8.50	23.86
24WCB	1.06	1.75	0.250	1.38	4.13	29.998	12	1 1/8-7	27.875	12.75	24.375	11.50	30.62
36WCB	1.52	2.58	0.280	2.38	4.97	44.498	16	1 3/8-6	41.500	16.50	18.375	16.50	44.86
48WCB	1.48	2.70	-	1	5.80	56.50	16	1 3/8-6	58.688	25.19	-	23.00	57.09
Size	D ₂₄	D ₂₅	D ₂₉	D ₄₆	D ₄₃	G	No. Size Bolt Circle			H ₁₀	H ₁₃	J ₁	J ₂
							H ₃	4					
8WCB	21	32	6.4	7	67	308,0	8	1/2-13	276,2	106	212,7	79	311
14WCB	23	36	6.4	8	74	476,3	8	3/4-10	431,8	181	365,1	152	481
18WCB	24	37	6.4	32	80	590,6	12	3/4-10	552,4	279	463,5	216	606
24WCB	27	44	6.4	35	105	761,9	12	1 1/8-7	708,0	324	619,1	292	778
36WCB	39	65	7,1	60	126	1130,2	16	1 3/8-6	1054,1	419	932,1	419	1139
48WCB	38	69	-	1	147	1435,0	16	1 3/8-6	1490,7	640	-	584	1450
SI	Dimensions in millimeters												

English	Dimensions in inches										
8WCB	3	1/4-20	3.500	3/8-18	6.63	TBD	TBD	TBD	TBD	TBD	
14WCB	3	3/8-16	6.500	1/2-14	11.50	1/2-14	13.250	3/8-18	8.250		
18WCB	3	3/8-16	9.125	1/2-14	15.25	1/2-14	15.750	3/8-18	11.630		
24WCB	6	3/8-16	12.250	1/2-14	18.50	1/2-14	20.500	3/8-18	14.500		
36WCB	6	1/2-13	14.500	3/4-14	28.00	3/4-14	28.000	3/8-18	22.250		
48WCB	3	3/4-10	24.500	1-11.5	41.500	1-11.5	41.500	0.5-14	31.500		
Size	No.	Size Bolt Circle			Size Bolt Circle		Dual Piston O ₂ 6				
		H ₄			Single Piston O ₂ 6		Large		Small		
	No.	Size	Bolt Circle	Size	Bolt Circle	Size	Bolt Circle	Size	Bolt Circle	Size	Bolt Circle
8WCB	3	1/4-20	88,9	3/8-18	168	TBD	TBD	TBD	TBD		
14WCB	3	3/8-16	165,1	1/2-14	292	1/2-14	337	3/8-18	210		
18WCB	3	3/8-16	231,8	1/2-14	387	1/2-14	400	3/8-18	295		
24WCB	6	3/8-16	311,2	1/2-14	470	1/2-14	521	3/8-18	368		
36WCB	6	1/2-13	444,5	3/4-14	711	3/4-14	711	3/8-18	565		
48WCB	3	3/4-10	622,3	1-11,5	1054,1	1-11,5	1054,1	0,5-14	800		
SI	Dimensions in millimeters										

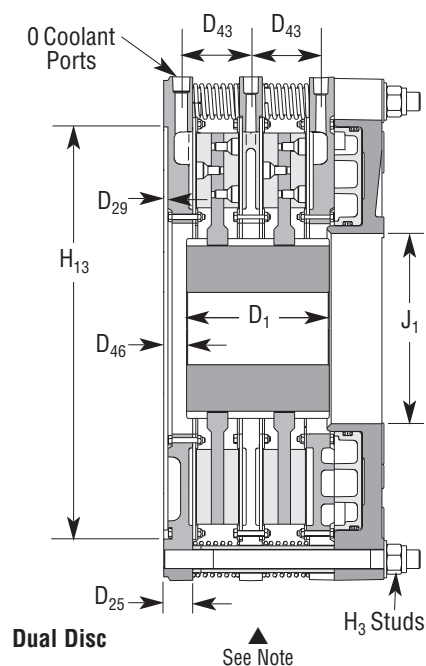
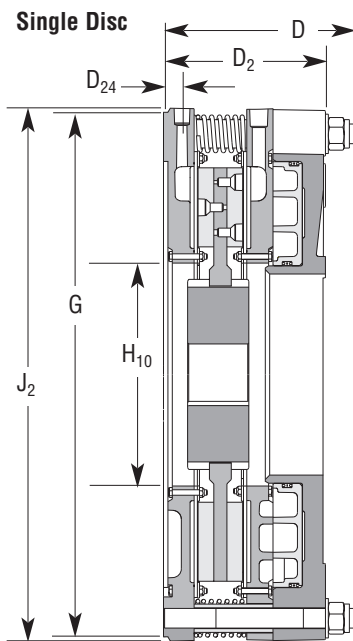

WCB2 & WCB4 Elements— Dimensional Data

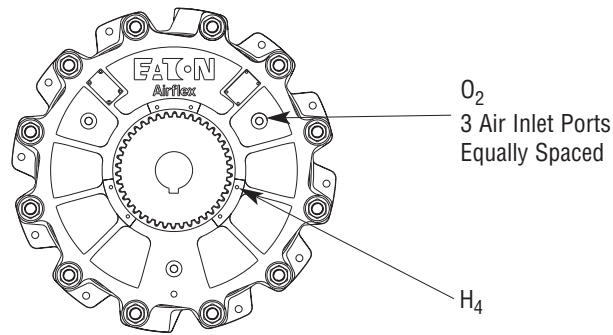

English	Dimensions in inches						
108WCB	1.50	2.56	7.00	1.75	5.69	4	3/8-18
208WCB	1.75	2.63	9.75	4.00	8.31	6	3/8-18
308WCB	2.00	2.50	12.88	7.75	10.95	8	3/8-18
114WCB	2.25	4.50	8.00	2.88	6.59	4	1/2-14
214WCB	2.75	4.38	11.50	4.38	9.50	6	1/2-14
314WCB	2.25	4.50	16.25	8.25	12.39	8	1/2-14
118WCB	2.88	5.56	9.00	2.50	7.32	4	1/2-14
218WCB	3.63	5.63	13.00	5.63	10.66	8	1/2-14
318WCB	4.25	5.81	17.25	9.63	14.00	12	1/2-14
418WCB	4.63	5.81	21.50	12.50	17.34	16	1/2-14
124WCB	3.75	7.25	11.00	3.50	9.26	4	3/4-14
224WCB	4.63	7.38	15.50	8.63	13.31	8	3/4-14
324WCB	5.38	7.50	24.00	13.19	17.38	12	3/4-14
424WCB	6.00	7.50	28.50	16.94	21.43	16	3/4-14
136WCB	5.63	11.25	17.00	5.00	12.07	4	1 1/4-11 1/2
236WCB	6.75	11.13	20.75	9.00	17.04	8	1 1/4-11 1/2
336WCB	7.75	11.13	27.48	13.00	22.00	12	1 1/4-11 1/2
436WCB	8.50	11.13	35.00	18.00	26.99	16	1 1/4-11 1/2
148WCB	7.13	16.13	16.57	5.00	14.42	4	1 1/4-11 1/2
248WCB	8.88	16.38	23.45	11.25	20.07	8	1 1/4-11 1/2
348WCB	10.25	16.38	30.70	16.75	25.71	12	1 1/4-11 1/2
448WCB	11.25	16.38	37.70	22.50	31.36	16	1 1/4-11 1/2

Size	Min.	Max.	D	D ₁	D ₂	No.	Size	
	Bore Range ⑨					O Coolant Ports ⑥	No.	Size
	Min.	Max.						
108WCB	38	65	178	44	145	4	3/8-18	
208WCB	44	67	248	102	211	6	3/8-18	
308WCB	51	64	327	196	278	8	3/8-18	
114WCB	57	114	203	73	167	4	1/2-14	
214WCB	70	111	292	111	241	6	1/2-14	
314WCB	57	114	413	210	315	8	1/2-14	
118WCB	73	141	229	64	186	4	1/2-14	
218WCB	92	143	330	143	271	8	1/2-14	
318WCB	108	148	438	245	356	12	1/2-14	
418WCB	117	148	546	318	440	16	1/2-14	
124WCB	95	184	279	89	235	4	3/4-14	
224WCB	117	187	394	219	338	8	3/4-14	
324WCB	137	191	610	335	441	12	3/4-14	
424WCB	152	191	724	430	544	16	3/4-14	
136WCB	143	286	432	17	307	4	1 1/4-11 1/2	
236WCB	171	283	527	229	433	8	1 1/4-11 1/2	
336WCB	197	283	698	330	559	12	1 1/4-11 1/2	
436WCB	216	283	889	457	686	16	1 1/4-11 1/2	
148WCB	181	410	421	127	366	4	1 1/4-11 1/2	
248WCB	225	416	596	286	510	8	1 1/4-11 1/2	
348WCB	260	416	780	425	653	12	1 1/4-11 1/2	

Notes:

- ❶ Only two ports, 180° apart, furnished on sizes 8 and 14WCB
 - ❷ To insure proper cooling, inlet port must be located at the six o'clock position.
 - ❸ Tolerance Sizes 8WCB thru 24WCB
+0.000/-0.003 (+0,00/-0,08)
36WCB +0.000/-0.005 (+0,00/-0,13)
48WCB +0.000/-0.005 (+0,00/-0,13)
 - ❹ American National Standard for Unified Screw Threads
 - ❺ Tolerance +0.003/-0.000 in.
(0,08/-0,00 mm)
 - ❻ American National Pipe Thread
 - ❼ 1.00 in (25 mm) for 108WCB
1.38 in (35 mm) for 208WCB
0.19 in (4,8 mm) for 308WCB
 - ❽ 1.06 in (27 mm) for 114WCB & 314WCB
1.69 in (43 mm) for 214WCB
 - ❾ Minimum bore sizes are based on flat keys, allowable gear hub stresses and torque ratings at 80 psi (5,5 bar).
 - ❿ Maximum diameter of "as cast" surfaces
 - ⓫ 1.96 in (50 mm) for 148WCB
1.75 in (44 mm) for 248WCB
1.75 in (44 mm) for 348WCB
1.75 in (44 mm) for 448WCB
- ▲ Some high torque applications of three or four disc elements require additional torsional support on the cylinder end of the unit. Contact your local Airflex representative for more details.

WCB2 & WCB3 Elements— Technical Data

English			lb-in @ 80 psi			HP	GPM		in ³							
108WCB	146455	146415	415313	5700	2900	2700	30	3	6.7E-02	0	3	20	2	11	2	10
208WCB	146456	146416	415314	11400	5900	5400	60	6	1.7E-0212	0	7	24	4	12	3	11
308WCB	146457	146417	416457	17100	8900	8100	90	9	7.4E-02	0	10	27	5	14	5	13
114WCB	146458	146418	415454	21500	16000	5400	60	6	2.4E-02	0	13	64	10	48	3	16
214WCB	146459	146419	415302	43000	32100	10800	120	12	6.0E-03	0	27	77	20	58	7	19
314WCB	146460	146420	416303	64500	48200	16300	180	18	2.6E-03	0	40	90	30	68	10	23
118WCB	146461	146421	302813	48800	36400	12300	120	12	1.9E-02	1.9E-01	17	124	13	93	4	31
218WCB	146462	146422	302907	97600	72900	24600	240	24	4.7E-03	9.5E-02	34	141	26	105	9	36
318WCB	146463	146423	413208	146400	109400	37000	360	36	2.1E-03	6.3E-02	51	158	38	118	13	40
418WCB	146464	146424	141111	195200	145800	49300	480	48	1.2E-03	4.8E-02	68	175	51	131	17	44
124WCB	146465	146425	411672	100000	72000	27000	270	27	4.3E-03	1.2E-01	31	204	23	148	9	56
224WCB	146466	146426	410970	20000	145000	54000	540	54	1.1E-03	6.1E-02	62	235	45	170	17	64
324WCB	146467	146427	412433	300000	217000	82000	810	81	4.8E-04	4.1E-02	93	266	68	193	26	73
424WCB	146468	146428	413195	400000	290000	109000	1080	108	2.7E-04	3.0E-02	124	297	90	215	34	82
136WCB	146469	146429	416538	295000	223000	71000	650	65	1.2E-03	8.9E-02	98	441	74	334	24	107
236WCB	146470	146430	416536	590000	446000	143000	1300	130	2.8E-04	5.8E-02	196	539	148	408	47	131
336WCB	146471	146413	416535	885000	670000	214000	1950	195	1.2E-04	3.9E-02	294	637	223	482	71	154
436WCB	146472	146431	416537	1180000	893000	286000	2600	260	6.9E-05	2.9E-02	392	734	297	556	95	178
148WCB	146473	146432	416794	686000	508000	178000	1300	130	1.1E-03	4.6E-02	221	574	163	425	57	149
248WCB	146474	146433	416795	1372000	1016000	356000	2600	260	2.3E-04	3.6E-02	441	795	327	589	115	206
348WCB	146475	146434	416688	2058000	1524000	534000	3900	390	1.0E-04	2.4E-02	662	1016	490	752	172	264
448WCB	146476	146435	416797	2744000	2032000	712000	5200	520	5.6E-05	1.8E-02	883	1236	654	915	229	321

Size	Part Number ①		Gear Part Number	Torque Rating Mr ②			③ Thermal Rating	④ Water Flow	⑤ Pressure Drop Coefficient		New	Worn	New	Worn	New	Worn			
	WCB2 Single Piston	WCB3 Dual Piston		Single Piston or both Pistons Together	Dual Piston				C1	C2							Single Piston or both Pistons Together	Dual Piston ⑥	
					Large Piston Only	Small Piston Only												Large Piston Only	Small Piston Only
						Large Piston Only			Small Piston Only	New							Worn	New	Worn
108WCB	146455	146415	415313	644	328	305	22,4	11,4	3,2E-04	0	0,05	0,33	0,03	0,18	0,03	0,16			
208WCB	146456	146416	415314	1288	667	610	44,7	22,7	8,2E-05	0	0,11	0,39	0,07	0,20	0,05	0,18			
308WCB	146457	146417	416457	1932	1006	915	67,2	34,2	7,4E-03	0	0,16	0,44	0,08	0,23	0,08	0,21			
114WCB	146458	146418	415454	2429	1808	610	44,7	22,7	1,2E-04	0	0,21	1,05	0,16	0,79	0,05	0,26			
214WCB	146459	146419	415302	4858	3627	1220	89,5	45,4	2,9E-05	0	0,44	1,26	0,33	0,95	0,11	0,31			
314WCB	146460	146420	416303	7288	5446	1842	134,4	68,4	2,6E-03	0	0,66	1,48	0,49	1,11	0,16	0,38			
118WCB	146461	146421	302813	5514	4113	1390	89,5	45,4	9,1E-05	3,5E-03	0,28	2,03	0,21	1,52	0,07	0,51			
218WCB	146462	146422	302907	11027	8237	2779	179,0	90,9	2,3E-05	1,7E-03	0,56	2,31	0,43	1,72	0,15	0,59			
318WCB	146463	146423	413208	16541	12361	4180	268	136	1,0E-05	1,2E-03	0,84	2,59	0,62	1,93	0,21	0,66			
418WCB	146464	146424	141111	22055	16473	5570	358	182	5,7E-06	8,7E-04	1,11	2,87	0,84	2,15	0,28	0,72			
124WCB	146465	146425	411672	11298	8135	3051	201,3	102,2	2,1E-05	2,2E-03	0,51	3,34	0,38	2,43	0,15	0,92			
224WCB	146466	146426	410970	22597	16383	6101	402,7	204,4	5,2E-06	1,1E-03	1,02	3,85	0,74	2,79	0,28	1,05			
324WCB	146467	146427	412433	33895	24518	9265	604	307	2,3E-06	7,4E-04	1,52	4,36	1,11	3,16	0,43	1,20			
424WCB	146468	146428	413195	45194	32766	12315	805	409	1,3E-06	5,6E-04	2,03	4,87	1,48	3,52	0,56	1,34			
136WCB	146469	146429	416538	33331	25196	8022	484,7	246,1	5,7E-06	1,6E-03	1,61	7,23	1,21	5,47	0,39	1,75			
236WCB	146470	146430	416536	66661	50391	16157	969,4	492,1	1,3E-06	1,1E-03	3,21	8,83	2,43	6,69	0,77	2,15			
336WCB	146471	146413	416535	99992	75700	24179	1454	738	5,9E-07	7,1E-04	4,82	10,44	3,657	7,90	1,16	2,52			
436WCB	146472	146431	416537	133322	100895	32314	1939	984	3,3E-07	5,3E-04	6,42	12,03	4,87	9,11	1,56	2,92			
148WCB	146473	146432	416794	77508	57396	20111	696	4921	5,2E-06	8,4E-04	3,62	9,41	2,67	6,97	0,93	2,44			
248WCB	146474	146433	416795	155015	114793	40223	1939	9840	1,1E-06	6,5E-04	7,23	13,03	5,36	9,65	1,88	3,38			
348WCB	146475	146434	416688	232523	172189	60334	2908	14763	4,8E-07	4,4E-04	10,85	16,65	8,03	12,33	2,82	4,33			
448WCB	146476	146435	416797	310030	229585	80445	3878	19684	2,7E-05	3,3E-03	14,47	20,26	10,72	15,00	3,75	5,26			

SI	Nm @ 5,5 bar			kW	dm ³ /min		dm ³							
----	--------------	--	--	----	----------------------	--	-----------------	--	--	--	--	--	--	--

Notes:

- ① Basic part number only. Order gear separately.
- ② Exact torque rating is dependent upon applied pressure. Maximum allowable pressure is 150 psi (10,3 bar).

③ Based upon a 70°F (21°C) fresh water inlet temperature and a 50°F (28°C) temperature rise between inlet and outlet. See cooling requirements.

④ To insure proper cooling, inlet port must be located at the six o'clock position. Maximum allowable inlet pressure is 45 psi (3,1 bar), 40 psi (2,7 bar) for 36WCB only.

WCB2 & WCB Elements— Technical Data

English	rpm		lb		in		lb·ft ²		in ³	
108WCB	2150	3400	61	19	3.17	2.05	9	0.8	12	10
208WCB	2150	3400	82	39	4.44	3.38	12	1.5	24	20
308WCB	2150	3400	120	59	5.55	4.55	15	2.33	36	30
114WCB	1260	2100	217	48	3.69	2.42	64	6.4	40	29
214WCB	1260	2100	284	86	5.26	3.83	83	12.6	75	58
314WCB	1260	2100	366	141	6.95	5.23	102	19.5	120	87
118WCB	955	1600	284	91	4.0	2.6	170	20	65	54
218WCB	955	1600	383	189	5.5	4.2	220	40	125	108
318WCB	955	1600	380	272	7.4	6.2	270	60	185	162
418WCB	955	1600	665	383	10	7.6	320	80	245	216
124WCB	715	1200	445	208	5.2	3.3	622	78	160	126
224WCB	715	1200	770	439	7.6	5.7	822	158	320	252
324WCB	715	1200	424	676	10	8	1022	238	480	378
424WCB	715	1200	413	887	12.4	10.1	1222	318	640	504
136WCB	475	700	2650	470	6.9	4.3	4922	324	600	337
236WCB	475	700	3250	855	9.5	6.8	6323	667	1135	673
336WCB	475	700	4350	1240	12.11	9.2	7724	1010	1670	1009
436WCB	475	700	5300	1655	14.67	11.8	9125	1353	2205	1345
148WCB	715	1200	3694	796	7.86	4.46	12024	1463	700	273
248WCB	715	1200	5035	1592	10.69	7.31	16205	2958	1400	546
348WCB	715	1200	6378	2383	13.53	10.11	20398	4434	2100	818
448WCB	715	1200	7719	3186	16.37	12.95	24583	5916	2800	1091

Size	Maximum Slip Speed ⑤	Maximum Freewheeling Speed ⑥	Weight		Center of Gravity ⑦		Wk ²		Water Volume	Lining Wear Volume
			Housing	Disc & Gear	Housing	Disc & Gear	Housing	Disc & Gear		
			Mass		Center of Gravity		J			
108WCB	2150	3400	28	9	81	52	0,38	0,3	0,2	0,2
208WCB	2150	3400	37	17	113	86	0,51	0,6	0,4	0,3
308WCB	2150	3400	54	27	141	116	0,64	0,04	0,6	0,4
114WCB	1260	2100	98	22	94	61	2,70	0,27	0,7	0,5
214WCB	1260	2100	129	39	134	97	3,50	0,53	1,2	1,0
314WCB	1260	2100	166	64	177	133	4,30	0,82	2,0	1,5
118WCB	955	1600	129	41	102	66	7,16	0,84	1,1	0,9
218WCB	955	1600	174	86	140	107	9,27	1,69	2,1	1,8
318WCB	955	1600	172	123	188	157	11,38	2,53	3,0	2,7
418WCB	955	1600	302	174	254	193	13,48	3,37	4,0	3,5
124WCB	715	1200	202	94	132	84	26,21	3,29	2,6	2,1
224WCB	715	1200	349	199	193	145	34,64	6,66	5,3	4,1
324WCB	715	1200	192	307	254	203	43,07	10,03	7,9	6,2
424WCB	715	1200	187	402	315	257	51,50	13,40	10,5	8,3
136WCB	475	700	1202	213	109	2,2	207,41	13,65	9,9	5,5
236WCB	475	700	1474	388	241	173	266,45	28,11	18,6	11,1
336WCB	475	700	1973	562	308	234	325,49	42,56	27,4	16,6
436WCB	475	700	2404	751	373	300	384,53	57,02	36,2	22,1
148WCB	715	1200	1676	361	200	113	506,70	61,65	11,5	4,5
248WCB	715	1200	2284	722	272	186	682,89	124,65	22,9	8,9
348WCB	715	1200	2893	1081	344	257	859,59	186,85	34,4	13,4
448WCB	715	1200	3501	1445	416	329	1035,95	249,31	45,9	17,9

SI	rpm		kg		mm		kg·m ²		dm ³	
----	-----	--	----	--	----	--	-------------------	--	-----------------	--

Notes:

⑤ Based upon a continuous slip velocity of 4500 fpm (22,9 mps).

⑥ Maximum freewheeling velocity is 7500 fpm (38,1 mps).

⑦ Located from mounting flange surface.

⑧ Absolute volume of cylinder at contact with new and worn friction discs.

⑨ Pressure drop coefficient based on maximum pressure drop across brake.

For More Information

Eaton's worldwide network of Sales Engineers and Distributors are ready to assist you with additional technical data or application information. Call the 800 number below for the name of your nearest Airflex sales office.
Call: **1-800-824-1586** or **FAX: 216-281-3890**



Eaton offers many other answers to your clutch and brake problems.

Write or call Eaton for a free copy of the Airflex 410 page engineering catalog which covers the complete line of Airflex clutches and brakes. It contains descriptions, dimensions, application information and technical data over nineteen types of clutches and brakes offered by Eaton. Ask for Catalog 800.

Headquarters:
Eaton Corporation
Airflex Division
9919 Clinton Road
Cleveland, Ohio 44144-1077
Phone: (216) 281-2211
FAX: (216) 281-3890



See our catalog at:
www.Airflex.com

Airflex® Clutches & Brakes

Catalog A-144a
2.5M501AP
Printed in U.S.A.

