

---

# WARNER

---

## *Magnetic Clutches and Brakes*



---

**WARNER ELECTRIC®**

**TEKMATIC**

Tel: (011) 4222-5040 Fax: (011) 4201-2478.  
info@tekmat.com.ar - www.tekmat.com.ar



## Fast, precise torque adjustment!

### Precision Tork™ clutches and brakes

Precision Tork units provide constant torque independent of slip speed. They offer excellent overload and jam protection for all drive train components and also provide soft starts with zero slip when a preset torque is reached. Precision Tork permanent magnet clutches and brakes do not require maintenance and provide extremely long life.

## Features and Benefits

### Fast, precise torque adjustment

- Torque is set with a large knurled adjustment ring.
- Infinite adjustability between minimum and maximum settings. This allows units to be fine tuned to your unique requirement.
- Easy to read graduations.

### Torque is constant with respect to speed

- By using the Precision Tork unit, you can solve almost any torque control problem.
- Torque is extremely consistent and smooth at low, as well as high speeds.

### No external control or power source

- Simple to install
- Nothing to monitor
- Unaffected by power interruption or power fluctuation
- Safe to use

### Dependable performance

- Smallest possible transition from static to dynamic torque. Virtually eliminates the "stick-slip" phenomenon associated with friction devices.
- Long life. The only wearing parts are the ball bearings.
- Extremely accurate. Precision Tork units out-perform all other devices at low RPM.

### Versatile mounting: Easy to retrofit

- Clutches are available with hollow bores for mounting on motor shafts or jack shafts.
- Bolt circles allow for fixed mounting, adding a pulley, or stub shaft adapters.
- Brakes are available with solid shaft outputs.

### Distributor item

- Off the shelf availability.
- Interchangeable with competitors' products.

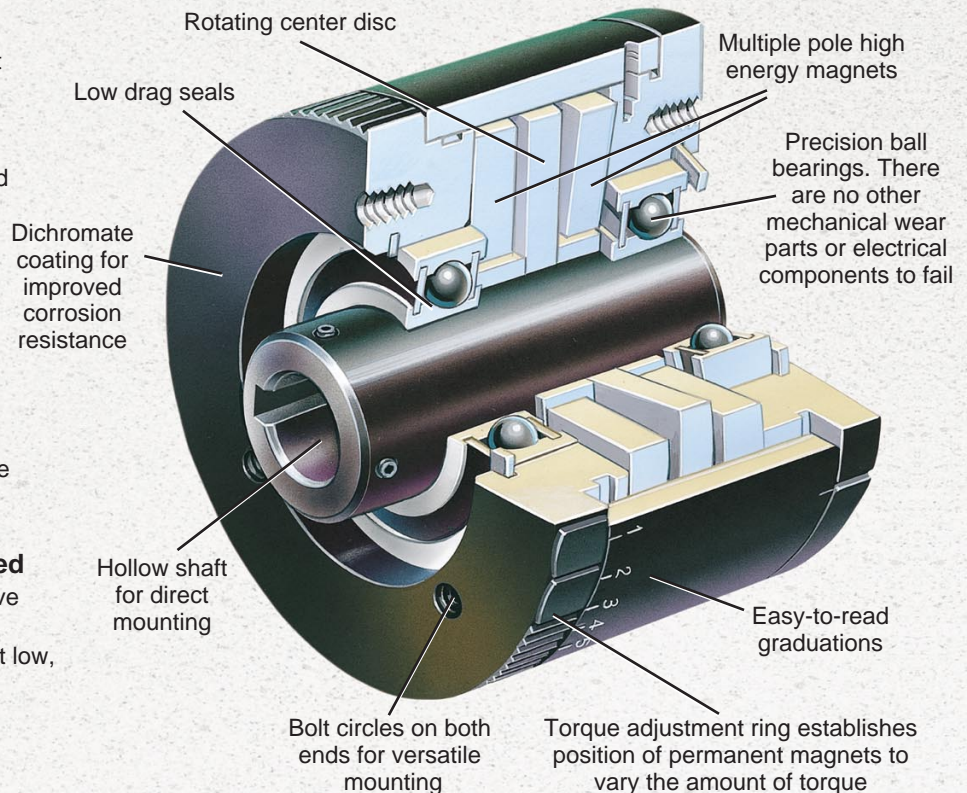

## Special Applications

### Specials are our business. . .

- Special shaft bores and keyways
- Shaft extensions
- System retrofits
- Metric bores and keyways
- Stainless steel construction
- Fixed torque units



MC4D

Long Shaft Extension

Stainless Steel



## Unwind tension control

Brake mounted on shaft of unwind spool or bobbin.

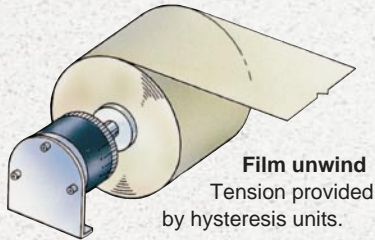

**Film unwind**  
Tension provided by hysteresis units.

### Information required:

Full roll diameter (in.) = 6 in.  
Core diameter (in.) = 4 in.  
Average tension (lbs.) = 4 lbs.  
Velocity (feet per min.) = 100 fpm

### How to size:

$$\text{Average radius (in.)} = \frac{\text{Full roll dia. (in.)} + \text{Core dia. (in.)}}{4}$$

$$= \frac{6 + 4}{4} = 2.5 \text{ in.}$$

Torque (lb.in.) =

$$\text{Avg. tension (lbs.)} \times \text{Avg. radius (in.)} = 4 \times 2.5 = 10 \text{ lb.in.}$$

Check tension range:

$$\text{Max. tension} = \text{Torque (lb.in.)} \times \frac{2}{\text{Core dia. (in.)}} = 10 \times \frac{2}{4} = 5 \text{ lbs.}$$

Min. tension = Torque (lb.in.) x

$$\frac{2}{\text{Full roll dia. (in.)}} = 10 \times \frac{2}{6} = 3.3 \text{ lbs.}$$

Slip watts =

$$\frac{\text{Max. tension (lbs.)} \times \text{velocity (fpm)}}{44.2}$$

$$= 11.3 \text{ watts}$$

**Select Model MC4**

## Cycling

### Bottle capping

Constant torque provided by a hysteresis clutch.

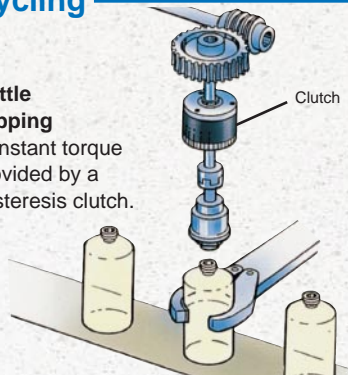

### Information required:

Slip RPM = 500 RPM  
Torque = 8 lb.in.  
% slip time of total cycle time = 25%

### How to size:

$$\text{*Watts} = .0118 \times \text{torque (lb.in.)} \times \text{slip RPM} \times \% \text{ slip time} = .0118 \times 8 \times 500 \times .25 = 11.8 \text{ watts}$$

Select an MC4 from the specification chart.

\*Note: Consult factory if peak slip watts are extremely high or if duration of slip period is in excess of 1 minute.

## Nip roll or pulley tension control

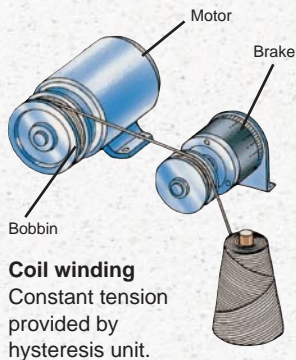

### Coil winding

Constant tension provided by hysteresis unit.

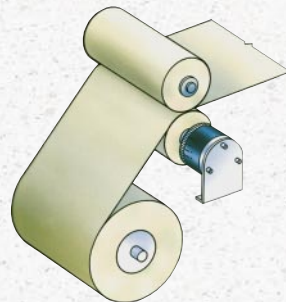

### Film tensioning

Constant tensioning supplied by hysteresis unit.

### Information required:

Pulley or nip roll diameter = 4 in. Tension = 6 lbs. Velocity = 100 fpm

### How to size:

$$\text{Torque (lb.in.)} = \text{Tension (lbs.)} \times \frac{\text{Dia. (in.)}}{2} = 6 \times \frac{4}{2} = 12 \text{ lb.in.}$$

$$\text{Slip watts} = \frac{\text{Tension (lbs.)} \times \text{velocity (fpm)}}{44.2} = \frac{6 \times 100}{44.2} = 13.5 \text{ watts}$$

**Select Model MC5**

## Overload protection/Torque limiting/Soft start

Motor horsepower method

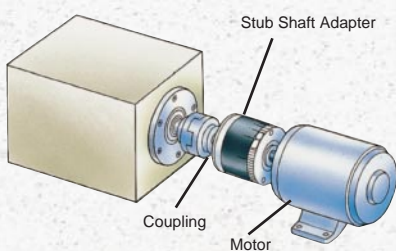

### Torque limiting

Hysteresis clutch provides overload protection.

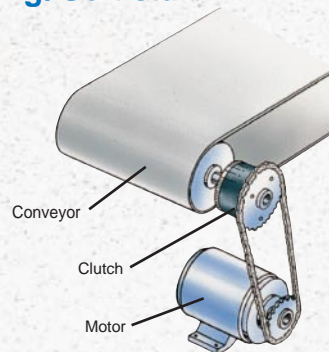

### Material handling

Hysteresis clutch can provide overload protection and soft start.

### Information required:

Motor HP = 1/2 HP  
Motor RPM = 1750 RPM

### How to size:

$$\text{Torque (lb.in.)} = \frac{\text{HP} \times 63000}{\text{RPM}} =$$

$$\frac{1/2 \times 63000}{1750} = 18 \text{ lb.in.}$$

Select an MC5 from the specification chart.



# Specifications



Tel: (011) 4222-5040 Fax: (011) 4201-2478.  
info@tekmatic.com.ar - www.tekmatic.com.ar

## Specifications

### Clutches



| Model Size | Torque          | Heat Dissipation (watts) | Inertia (oz. in. sec. <sup>2</sup> ) | Bending Moment (lb. in.) | Max. RPM | Weight (lbs.) | Bore Range/Shaft Dia. (in.) |
|------------|-----------------|--------------------------|--------------------------------------|--------------------------|----------|---------------|-----------------------------|
| MC2        | 1–20 oz. in.    | 10                       | $0.7 \times 10^{-3}$                 | 5                        | 3600     | 11 oz.        | 1/4                         |
| MC3        | 0.3–5.0 lb. in. | 18                       | $6.5 \times 10^{-3}$                 | 10                       | 1800     | 2             | 3/8                         |
| MC4        | 0.5–10 lb. in.  | 22                       | $13.3 \times 10^{-3}$                | 10                       | 1800     | 2.5           | 3/8, 1/2, 5/8               |
| MC5        | 1–25 lb. in.    | 72                       | $77 \times 10^{-3}$                  | 25                       | 1800     | 9             | 3/8, 1/2, 5/8, 3/4, 7/8, 1  |
| MC5.5      | 1–45 lb. in.    | 110                      | $120 \times 10^{-3}$                 | 25                       | 1800     | 11            | 5/8, 3/4, 7/8, 1            |
| MC6        | 2–65 lb. in.    | 150                      | $196 \times 10^{-3}$                 | 25                       | 1800     | 12            | 5/8, 3/4, 7/8, 1            |

### Brakes



|       |                 |     |                       |    |      |        |      |
|-------|-----------------|-----|-----------------------|----|------|--------|------|
| MB1   | 0-1.1 oz. in.   | 3   | $3.5 \times 10^{-5}$  | 1  | 3600 | 2 oz.  | 3/16 |
| MB2   | 1–20 oz. in.    | 10  | $0.9 \times 10^{-3}$  | 5  | 3600 | 11 oz. | 1/2  |
| MB3   | 0.3–5.0 lb. in. | 18  | $6.9 \times 10^{-3}$  | 10 | 1800 | 2      | 3/8  |
| MB4   | 0.5–10 lb. in.  | 22  | $13.7 \times 10^{-3}$ | 10 | 1800 | 2.5    | 5/8  |
| MB5   | 1–25 lb. in.    | 72  | $82 \times 10^{-3}$   | 25 | 1800 | 9      | 1    |
| MB5.5 | 1–45 lb. in.    | 110 | $125 \times 10^{-3}$  | 25 | 1800 | 11     | 1    |
| MB6   | 2–65 lb. in.    | 150 | $201 \times 10^{-3}$  | 25 | 1800 | 12     | 1    |

## Typical Mounting Arrangements

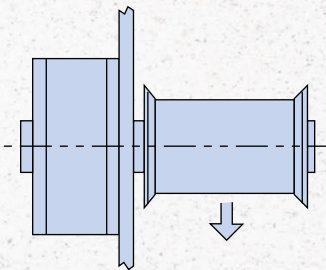

**Brake:**  
Typical setup for tensioning wire, film and fibers.

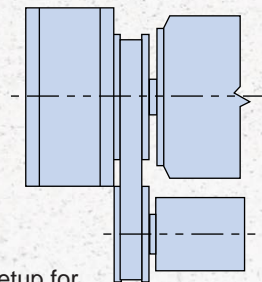

**Clutch:**  
Typical setup for material handling, soft starts and torque limiting.

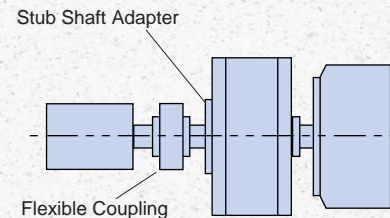

**Clutch Coupling:**  
Typical setup for torque limiting protection used for labeling, capping and printing applications.



# Heat Dissipation Charts



Tel: (011) 4222-5040 Fax: (011) 4201-2478.  
info@tekmatic.com.ar - www.tekmatic.com.ar

## Clutches/Brakes

**MB1**

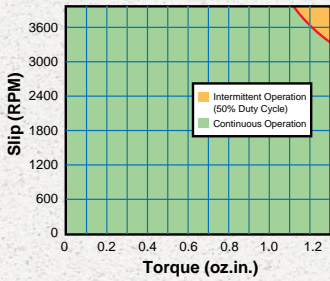

**MC2/MB2**

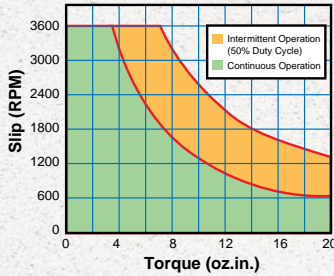

**MC3/MB3**

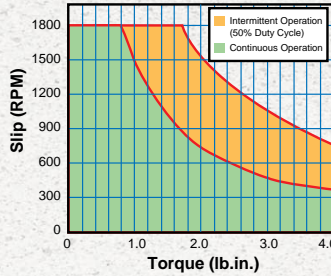

**MC4/MB4**

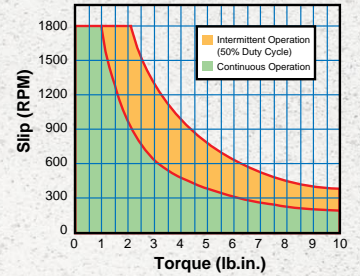

**MC5/MB5**

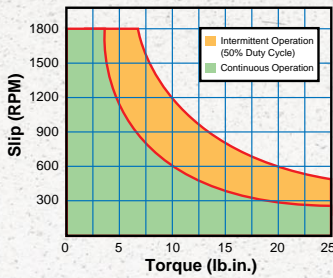

**MC5.5/MB5.5**

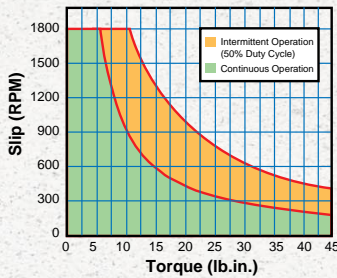

**MC6/MB6**

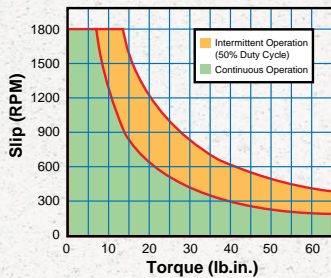

# Torque Setting Charts

## Clutches/Brakes

**MB1**

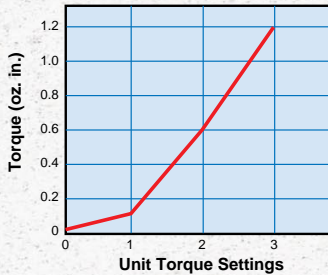

**MC2/MB2**

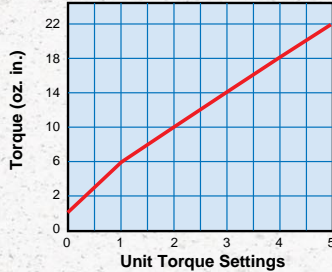

**MC3/MB3**

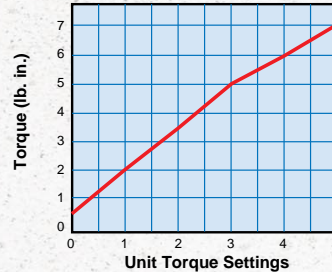

**MC4/MB4**

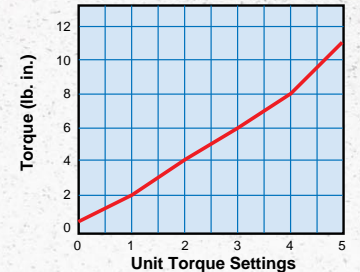

**MC5/MB5**

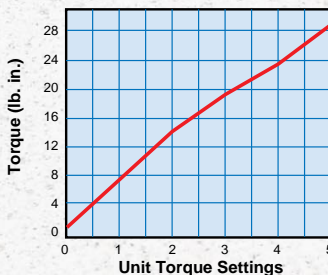

**MC5.5/MB5.5**

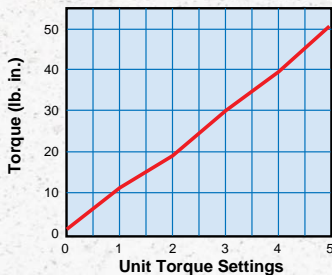

**MC6/MB6**

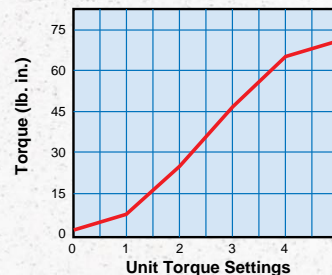



# Magnetic Clutch Units



Tel: (011) 4222-5040 Fax: (011) 4201-2478.  
info@tekmatic.com.ar - www.tekmatic.com.ar

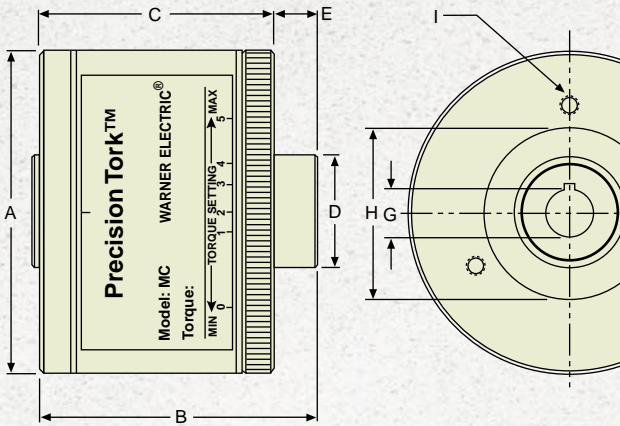

**Drawing A**

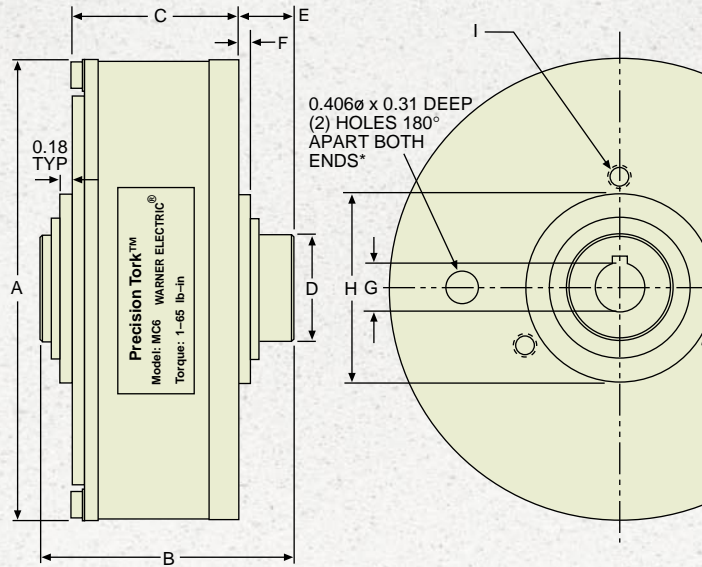

**Drawing B**

\*Set screw adjustment

\*Spanner wrench adjustment

| Model | Drawing | A    | B    | C    | D     | E    | F    |
|-------|---------|------|------|------|-------|------|------|
| MC2   | A       | 1.85 | 1.61 | 1.35 | 0.375 | 0.26 | –    |
| MC3   | A       | 2.75 | 2.24 | 2.00 | 0.590 | 0.24 | –    |
| MC4   | A       | 3.23 | 2.26 | 2.00 | 0.984 | 0.26 | –    |
| MC5   | A       | 4.65 | 3.18 | 2.65 | 1.378 | 0.42 | –    |
| MC5.5 | A       | 5.29 | 3.25 | 2.65 | 1.378 | 0.60 | –    |
| MC6   | B       | 6.10 | 3.18 | 2.27 | 1.378 | 0.55 | 0.18 |

## Bore & Keyseat Sizes

| Model | Keyseat     | Lockdown Method | G   | H                     | I                              |
|-------|-------------|-----------------|-----|-----------------------|--------------------------------|
| MC2   | None        | 3/32 Roll Pin   | 1/4 | 0.875/0.874 x 0.80 dp | 3) 6-32 x 5/16 dp 1.25 B.C.    |
| MC3   | None        | 2) Set Screws   | 3/8 | 1.383/1.381 x .120 dp | 3) 10-32 x 7/16 dp 1.875 B.C.  |
| MC4   | None        | 3/32 Roll Pin   | 3/8 | 1.850x1.849 x 0.80 dp | 3) 10-32 x 7/16 dp 2.375 B.C.  |
|       | 1/8 Key     | 2) Set Screws   | 1/2 |                       |                                |
| MC5   | 3/16 Key    | 2) Set Screws   | 5/8 | 2.441/2.440 x .100 dp | 3) 10-32 x 1/2 dp 3.00 B.C.    |
|       | 1/8 Key     | 2) Set Screws   | 1/2 |                       |                                |
|       | 3/16 Key    | 2) Set Screws   | 3/4 |                       |                                |
|       | 3/16 Key    | 2) Set Screws   | 7/8 |                       |                                |
|       | 1/4 Shallow | 2) Set Screws   | 1   |                       |                                |
| MC5.5 | 3/16 Key    | 2) Set Screws   | 5/8 | 2.441/2.440 x .100 dp | 3) 10-32 x 1/2 dp 3.00 B.C.    |
|       | 3/16 Key    | 2) Set Screws   | 3/4 |                       |                                |
|       | 3/16 Key    | 2) Set Screws   | 7/8 |                       |                                |
| MC6   | 1/4 Shallow | 2) Set Screws   | 1   | 2.441                 | 3) 1/4-20 x 5/16 dp 2.875 B.C. |
|       | 3/16 Key    | 2) Set Screws   | 5/8 |                       |                                |
|       | 3/16 Key    | 2) Set Screws   | 3/4 |                       |                                |
|       | 3/16 Key    | 2) Set Screws   | 7/8 |                       |                                |



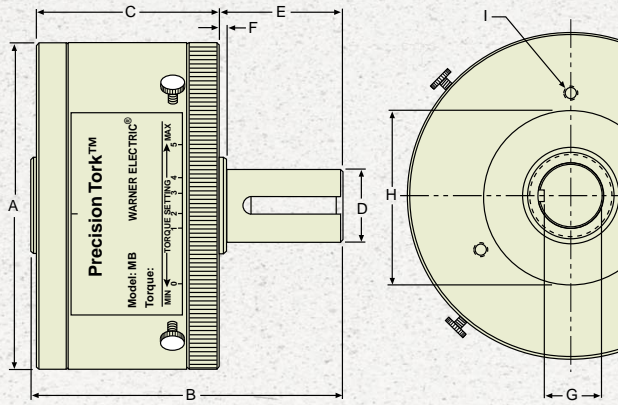

**Drawing C**

\*Thumb screw adjustment

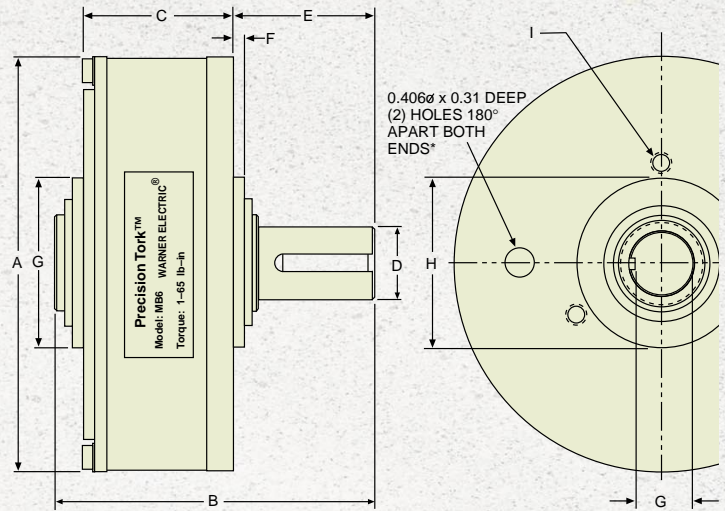

**Drawing D**

\*Spanner wrench adjustment

| Model | Drawing | A    | B    | C    | D    | E    | F    | G           | H                      | I                              |
|-------|---------|------|------|------|------|------|------|-------------|------------------------|--------------------------------|
| MB1   | C       | 1.02 | 1.43 | 0.85 | 3/16 | 0.58 | -    | 0.170 Flat  | 0.301/0.302 x 0.100 dp | 3) 4-40 x 1/4 dp 0.610 B.C.    |
| MB2   | C       | 1.85 | 2.35 | 1.35 | 1/4  | 1.00 | -    | 0.230 Flat  | 0.875/0.874 x 0.80 dp  | 3) 6-32 x 5/16 dp 1.250 B.C.   |
| MB3   | C       | 2.75 | 3.02 | 2.00 | 3/8  | 1.03 | 0.03 | 0.350 Flat  | 1.383/1.381 x 0.12 dp  | 3) 10-32 x 7/16 dp 1.875 B.C.  |
| MB4   | C       | 3.23 | 2.97 | 2.00 | 5/8  | 0.97 | 0.09 | 0.518/0.503 | 1.850/1.849 x 0.08dp   | 3) 10-32 x 7/16 dp 2.375 B.C.  |
| MB5   | C       | 4.65 | 4.50 | 2.75 | 1    | 1.75 | 0.11 | 0.859/0.844 | 2.441/2.440 x 0.100 dp | 3) 10-32 x 1/2 dp 3.000 B.C.   |
| MB5.5 | C       | 5.29 | 4.50 | 2.85 | 1    | 1.75 | 0.25 | 0.859/0.844 | 2.441/2.440 x 0.100 dp | 3) 10-32 x 1/2 dp 3.000 B.C.   |
| MB6   | D       | 6.10 | 4.50 | 2.75 | 1    | 1.75 | 0.43 | 0.859/0.844 | 2.441                  | 3) 1/4-20 x 5/16 dp 2.875 B.C. |





- Utilized when "clutch coupling" configuration is desired.
- Comes complete with attachment hardware and drive key.
- Stub shaft adapters should be used in conjunction with a flexible coupling.

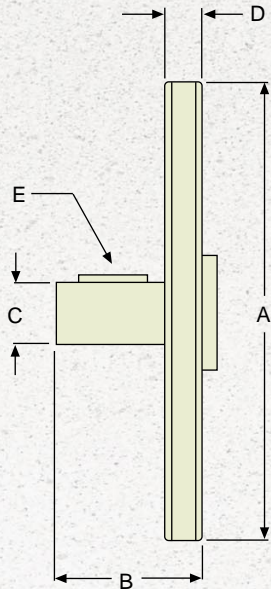

| Model Size | Clutch Model | A    | B    | C   | D    | E         |
|------------|--------------|------|------|-----|------|-----------|
| A2-14      | MC2          | 1.60 | 0.78 | 1/4 | 0.15 | Flat      |
| A3-38      | MC3          | 2.36 | 1.19 | 3/8 | 0.19 | Flat      |
| A4-38      | MC4          | 2.86 | 1.19 | 3/8 | 0.19 | Flat      |
| A5-12      | MC5, MC5.5   | 3.45 | 1.47 | 1/2 | 0.27 | 1/8" Key  |
| A6-34      | MC6          | 3.40 | 1.70 | 3/4 | 0.35 | 3/16" Key |

## How to Order

### 1. Torque:

Determine the maximum torque that your application requires. See the application example.

### 2. Energy Dissipation:

Determine the amount of energy or heat that will be generated during operation. Each clutch or brake is rated for a specific amount of

energy, given in units of watts, that it can safely dissipate. Energy calculations for common applications are listed in the applications section.

### 3. Model Selection:

Select the clutch or brake based on torque and energy requirements. See the specifications under "Heat Dissipation and Torque Setting Charts."

### 4. Select Bore Size:

Select the proper bore size for the application. Although many standard bores are available, consult the factory if your bore requirement is not listed.

### 5. Example:

Torque Requirement – 9 lb.in.  
 Energy Requirement – 35 watts  
 Bore Requirement – 5/8 inch  
 Select Model MC5-58

# WARNER ELECTRIC®

449 Gardner Street, South Beloit, IL 61080  
 Phone 815/389-6691 • FAX 815/389-2582