

I
Limitatori di coppia assiali a scorrimento sfere

GB
Ball-sliding axial release torque limiters

LASS...

F
Limiteurs de couple axiaux à billes.

D
Axiale Kugelumlauf-Drehmomentbegrenzer

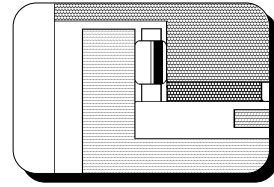

DET. X

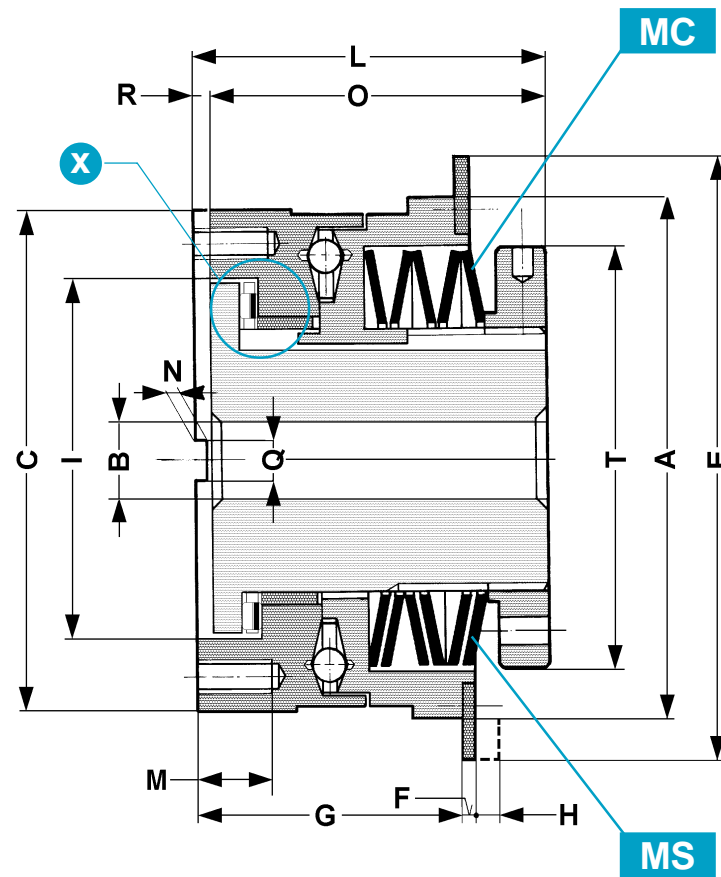
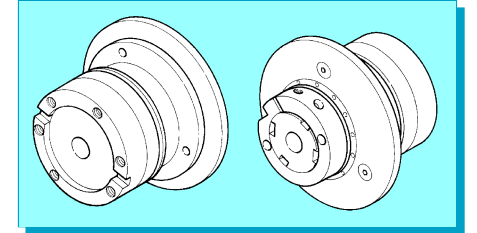

A RICHIESTA VERSIONE A RULLI CONTINUI CON COPPIE SUPERIORI
CONTINUOUS ROLLERS VERSION WITH HIGHER TORQUES AVAILABLE ON REQUEST

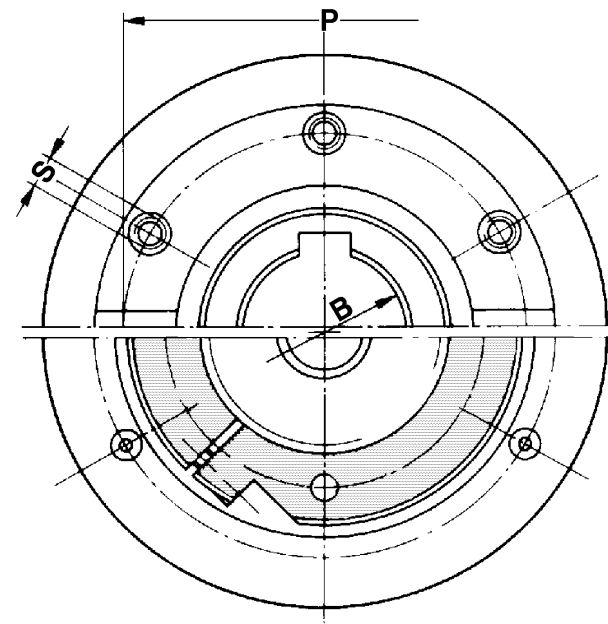

(SOLO LASS/70 VERSIONE C)
(Only LASS/70, Version C)

Velocità massima - giri/min.
Max Speed - rpm

70	4.350
90	2.940
110	2.400
130	2.000
160	1.750
200	1.400

TEKMATIC

Tel: (011) 4222-5040 Fax: (011) 4201-2478.
info@tekmatic.com.ar - www.tekmatic.com.ar

LASS...	cod. A	cod. B	cod. C
70	30.01AC.A0	30.01BC.A0	30.01CS.A0
90	30.01AC.B0	30.01BC.B0	30.01CC.B0
110	30.01AC.C0	30.01BC.C0	30.01CC.C0
130	30.01AC.D0	30.01BC.D0	30.01CC.D0
160	30.01AC.E0	30.01BC.E0	30.01CC.E0
200	30.01AC.F0	30.01BC.F0	30.01CC.F0

LASS...	Nm	N°m	Tm	A	B		C	E	F	G	H	I ^{H7}	L	M	N	O	P	Q	R	S	T	Kg	
					min	max																	
70	A	2,5 ÷ 5	5	0/1	66	8	20	55	80	3	30	1,4	41	46	8	3	42	48	6	4	M 5	42	0,800
	B	5 ÷ 10	5	0/2																			
	C	10 ÷ 20	6	0/2																			
90	A	6 ÷ 12	7	1/1	90	10	25	85	105	3	47	2	60	62	12	3	58	72	6	4	M 6	63	2,000
	B	12 ÷ 25	5	1/2																			
	C	25 ÷ 50	5	1/3																			
110	A	12 ÷ 25	6	2/1	110	15	35	105	130	4	57	3	80	74	15	3,5	70	92	8	4	M 6	82	3,800
	B	25 ÷ 50	5	2/2																			
	C	50 ÷ 100	4	2/3																			
130	A	25 ÷ 50	6	3/1	130	20	45	125	150	4	69	3	90	86	15	4	82	108	10	4	M 8	105	6,600
	B	50 ÷ 100	5	3/2																			
	C	100 ÷ 200	4	3/3																			
160	A	50 ÷ 100	6	4/1	160	25	55	148	180	4	85	3,5	105	105	20	4	99	125	12	6	M 10	129	11,200
	B	100 ÷ 200	5	4/2																			
	C	200 ÷ 400	4	4/3																			
200	A	90 ÷ 180	7	5/1	194	28	65	176	220	4	98	4,5	120,5	124,5	20	4,5	118	155	14	6,5	M 12	159	19,200
	B	180 ÷ 350	5	5/2																			
	C	350 ÷ 700	5	5/3																			

I
Limitatori di coppia assiali a scorrimento con fase

GB
Sliding axial torque limiters with synchronization

LASS.../F

F
Limiteurs de couple axiaux à coulissement à phase

D
Axiale Drehmomentbegrenzer mit Verschiebung und Synchronisierung

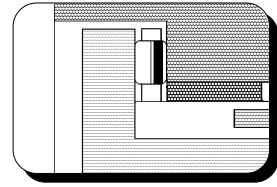
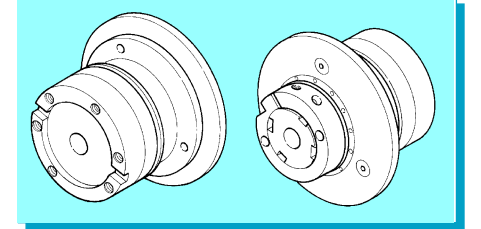

DET. X

A RICHIESTA VERSIONE A RULLI CONTINUI CON COPPIE SUPERIORI
CONTINUOUS ROLLERS VERSION WITH HIGHER TORQUES AVAILABLE ON REQUEST

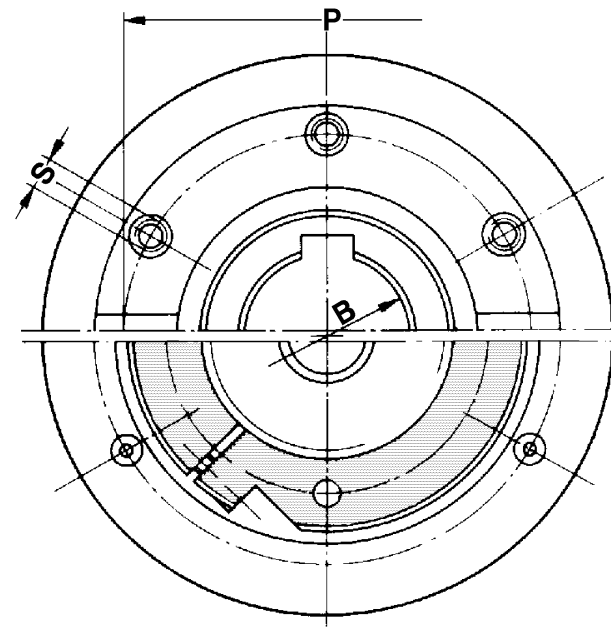
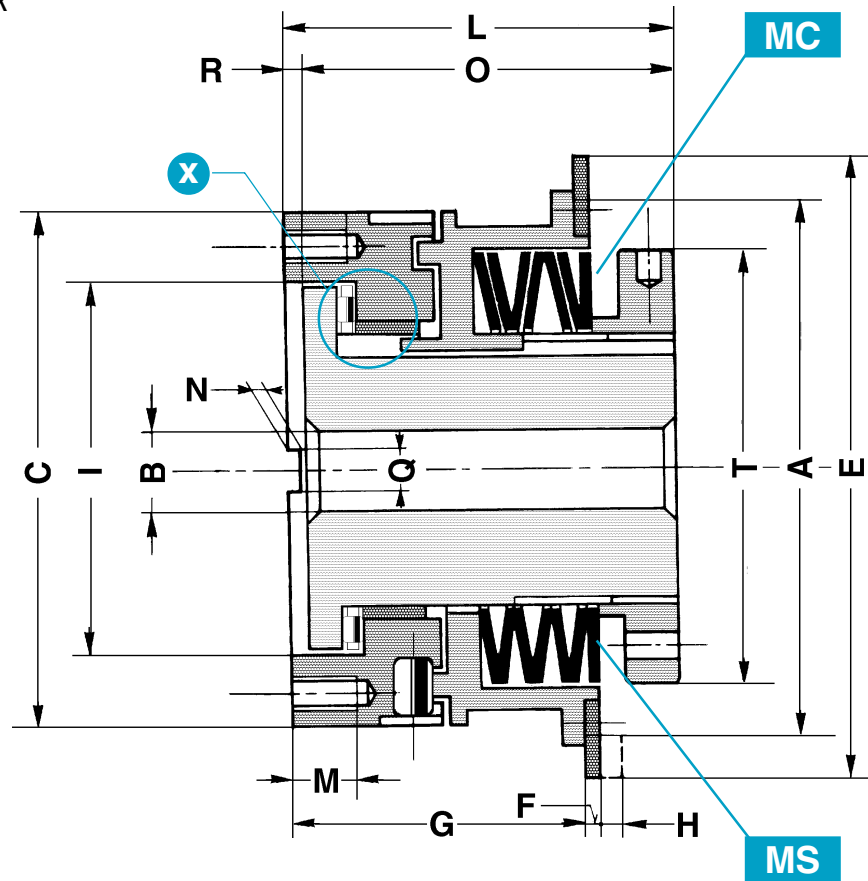

(SOLO LASS 70/F VERSIONE C)
(Only LASS 70/F, Version C)

Velocità massima - giri/min.
Max Speed - rpm

70	4.350
90	2.940
110	2.400
130	2.000
160	1.750
200	1.400

TEKMATIC

Tel: (011) 4222-5040 Fax: (011) 4201-2478.
info@tekmatic.com.ar - www.tekmatic.com.ar

LASS.../F	cod. A	cod. B	cod. C
70	30.02AC.A0	30.02BC.A0	30.02CS.A0
90	30.02AC.B0	30.02BC.B0	30.02CC.B0
110	30.02AC.C0	30.02BC.C0	30.02CC.C0
130	30.02AC.D0	30.02BC.D0	30.02CC.D0
160	30.02AC.E0	30.02BC.E0	30.02CC.E0
200	30.02AC.F0	30.02BC.F0	30.02CC.F0

LASS.../F	Nm	N°m	Tm	A	B		C	E	F	G	H	I ^{H7}	L	M	N	O	P	Q	R	S	T	Kg	
					min	max																	
70	A	5 ÷ 10	5	0/1	66	8	20	55	80	3	30	1,2	41	46	8	3	42	48	6	4	M5	42	0,800
	B	10 ÷ 20	5	0/2																			
	C	20 ÷ 40	6	0/2																			
90	A	12 ÷ 25	7	1/1	90	10	25	85	105	3	46	2	60	62	12	3	58	72	6	4	M6	63	2,000
	B	25 ÷ 50	5	1/2																			
	C	50 ÷ 100	5	1/3																			
110	A	25 ÷ 50	6	2/1	110	15	35	105	130	4	56	2,3	80	74	15	3,5	70	92	8	4	M6	82	3,800
	B	50 ÷ 100	5	2/2																			
	C	100 ÷ 200	4	2/3																			
130	A	50 ÷ 100	6	3/1	130	20	45	125	150	4	68	3	90	86	15	4	82	108	10	4	M8	105	6,600
	B	100 ÷ 200	5	3/2																			
	C	200 ÷ 400	4	3/3																			
160	A	100 ÷ 200	6	4/1	160	25	55	148	180	4	85	3	105	105	20	4	99	125	12	6	M10	129	11,200
	B	200 ÷ 400	5	4/2																			
	C	400 ÷ 800	4	4/3																			
200	A	175 ÷ 350	7	5/1	194	28	65	176	220	4	98	3	120,5	124,5	20	4,5	118	155	14	6,5	M12	159	19,200
	B	350 ÷ 700	5	5/2																			
	C	700 ÷ 1400	4	5/3																			

